

# Organizacija berbe

# Sanitarni uslovi

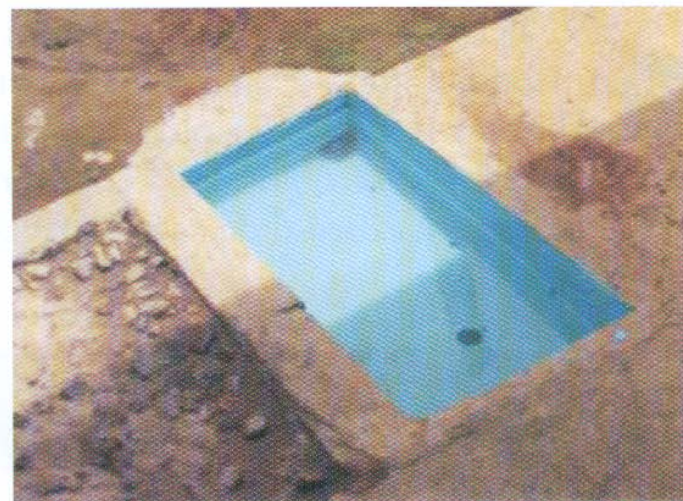
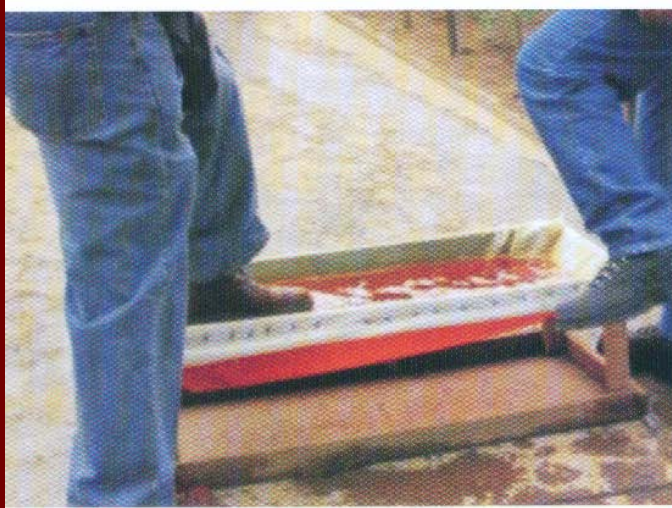

# Pripreme za berbu -planiranje-

---

- ❑ U pripremnim radnjama obezbijediti radnu snagu, mašine, ambalažu i obuku osoblja
- ❑ Posebna pažnja se poklanja bezbjednosnim standardima







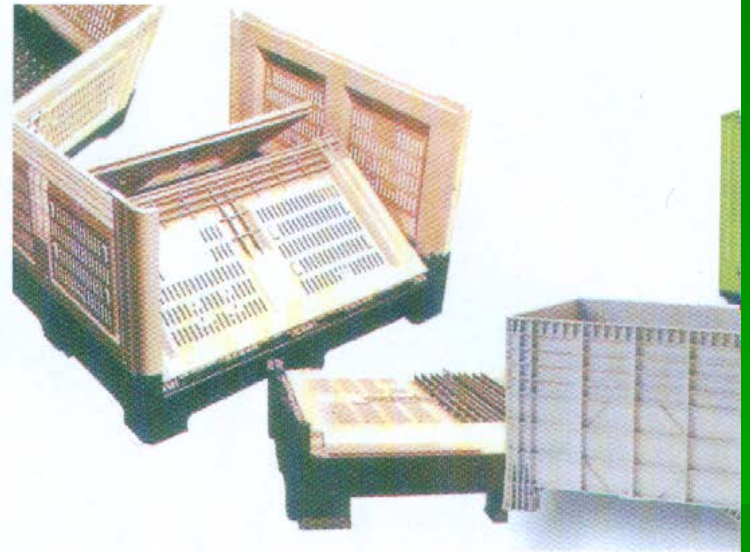



# Neposredni početak berbe

---



# Prognoza prinosa, potrebne radne snage i skladišnog prostora

## Prethodna prognoza prinosa:

- utvrđivanje namjene plodova
- planira se neophodna ambalaža

## Radna snaga

- predviđanje radnog učinka
- mjere stimulacije



Ambalaža i  
oprema za  
berbu nikada  
ne smiju biti  
na zemlji





# Berba

- Osnovni cilj berbe voća je prikupljanje plodova iz voćnjaka u optimalnom stadijumu zrelosti uz minimalne gubitke i oštećenja
- Berbu treba obaviti što je moguće brže i uz najmanje moguće troškove
- Berba može biti:
  - mehanizovana
  - polumehanizovana
  - ručna

# Mehanizovana berba

---

- Ima prednosti i mane
  - **Prednosti:**
    - Velika brzina rada i učinci
    - Manje radne snage i obuke
    - Manja logistika (ishrana, prevoz, smještaj, toaleti itd.)
    - Jeftinija berba
  - **Mane:**
    - Specijalizacija mašina
    - Oštećenja plodova
    - Mehanizacija je skupa
    - Sistem gajenja se mora prilagoditi karakteristikama mašine
-

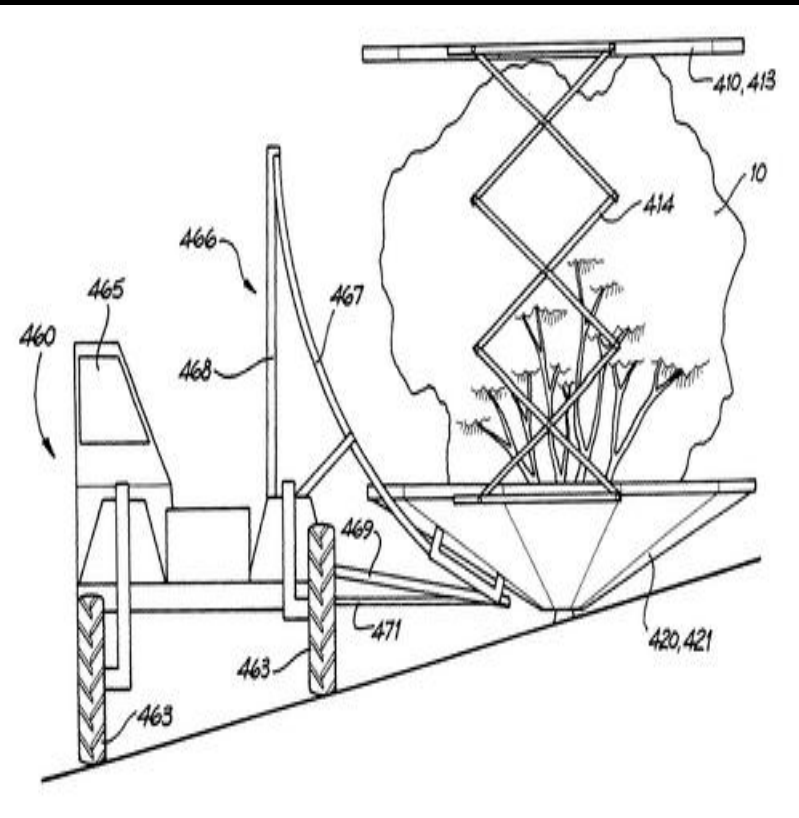



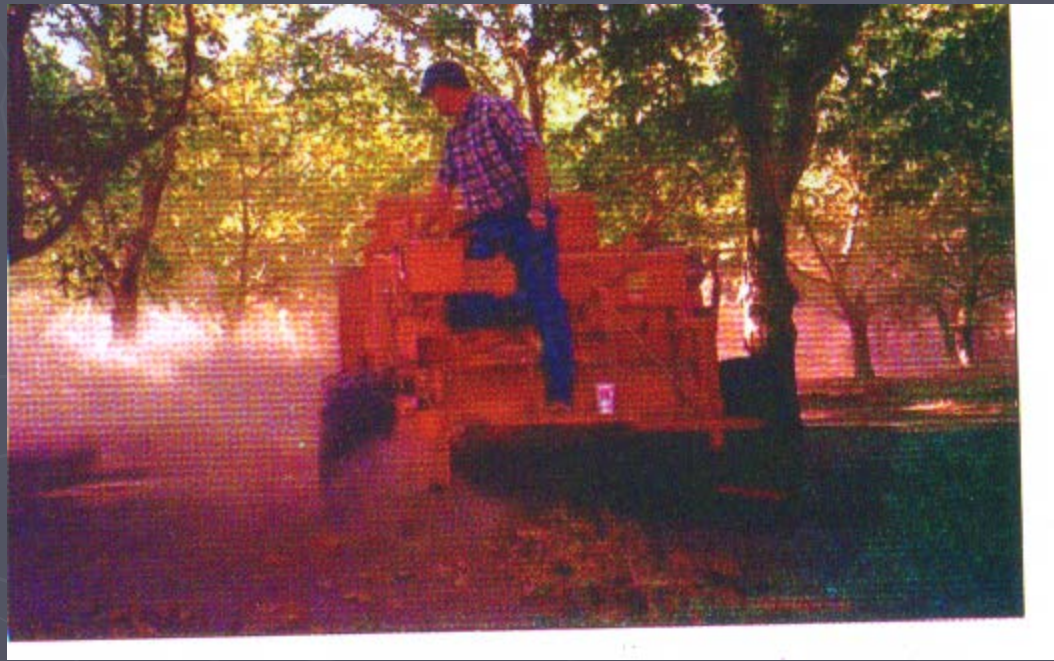









# U budućnosti – roboti?

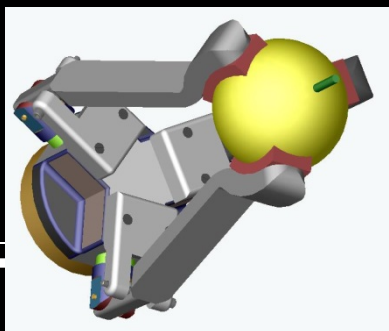

# Polumehanizovana berba

- Radi se o ručnoj berbi uz uporebu određenih mehanizovanih pomagala:
  - platforme
  - pokretne trake
  - reflektori

- 
- Različiti tipovi platformi i konvejera







# Ručna berba

## ■ Prednosti:

- Berba se obavlja uz minimalna oštećenja
- Berba je precizna i selektivna
- Mogućnost prilagođavanja potrebama
- Ne oštećuju se dijelovi stabla

## ■ Mane:

- Nedostatak radne snage
- Logistika (ishrana, smještaj itd.)
- kontrola i stimulacija

# Ovo bi trebalo zaboraviti





# Probirna berba i prva selekcija





# Uvijek rad učiniti lakšim









# Kengur torbe





# Adekvatna ambalaža

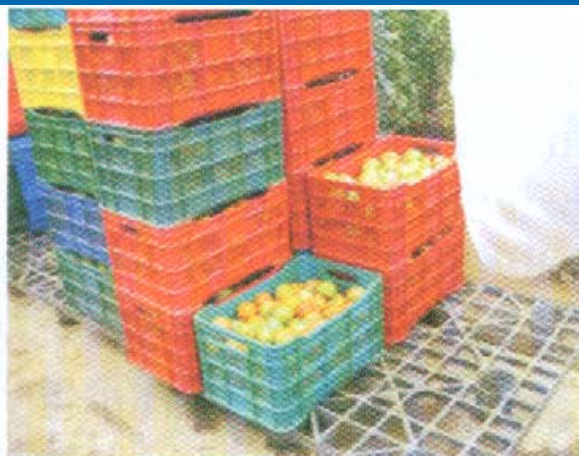
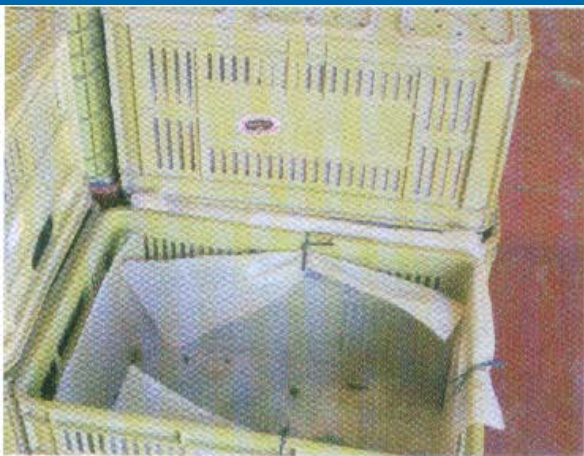
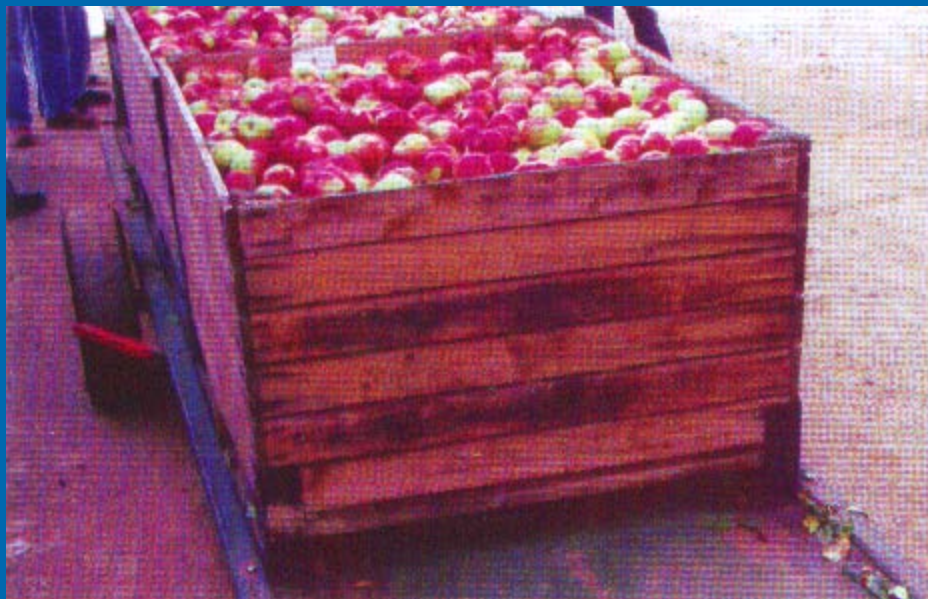



Unutrašnjost ambalaže uvijek  
obložiti mekim materijalom



# Transport u zasadu

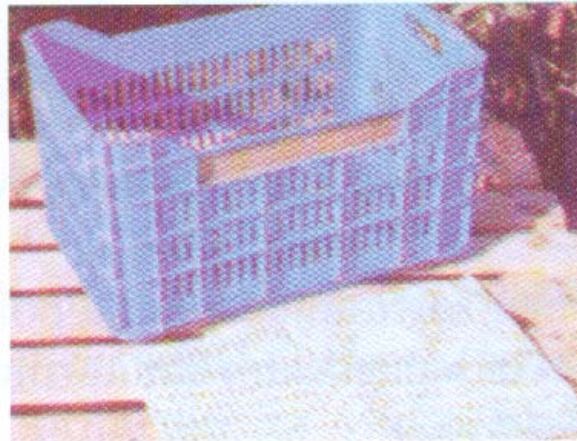



# Hladiti što prije!

